

DEWALT®

Fig. A1

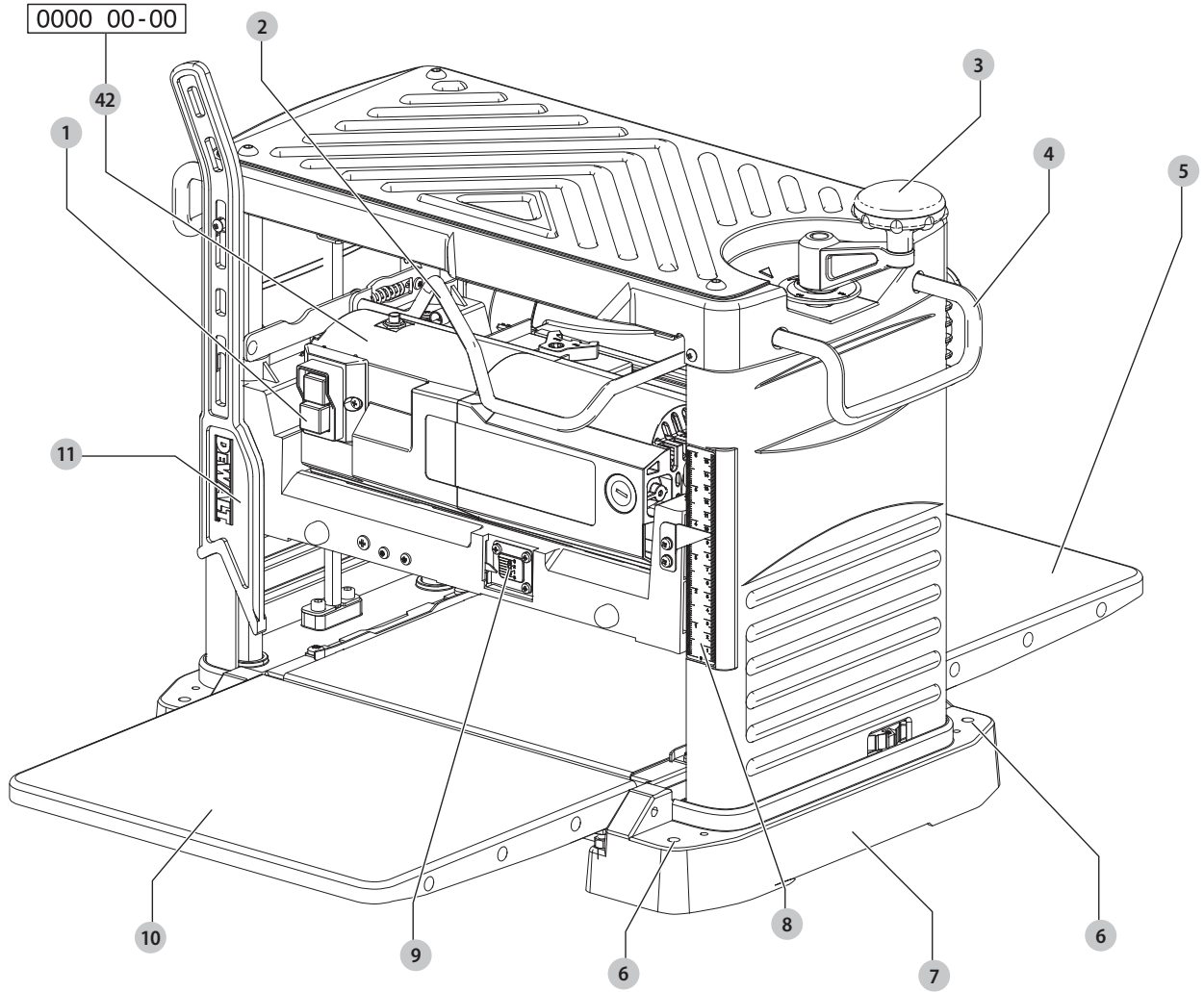

Fig. A2

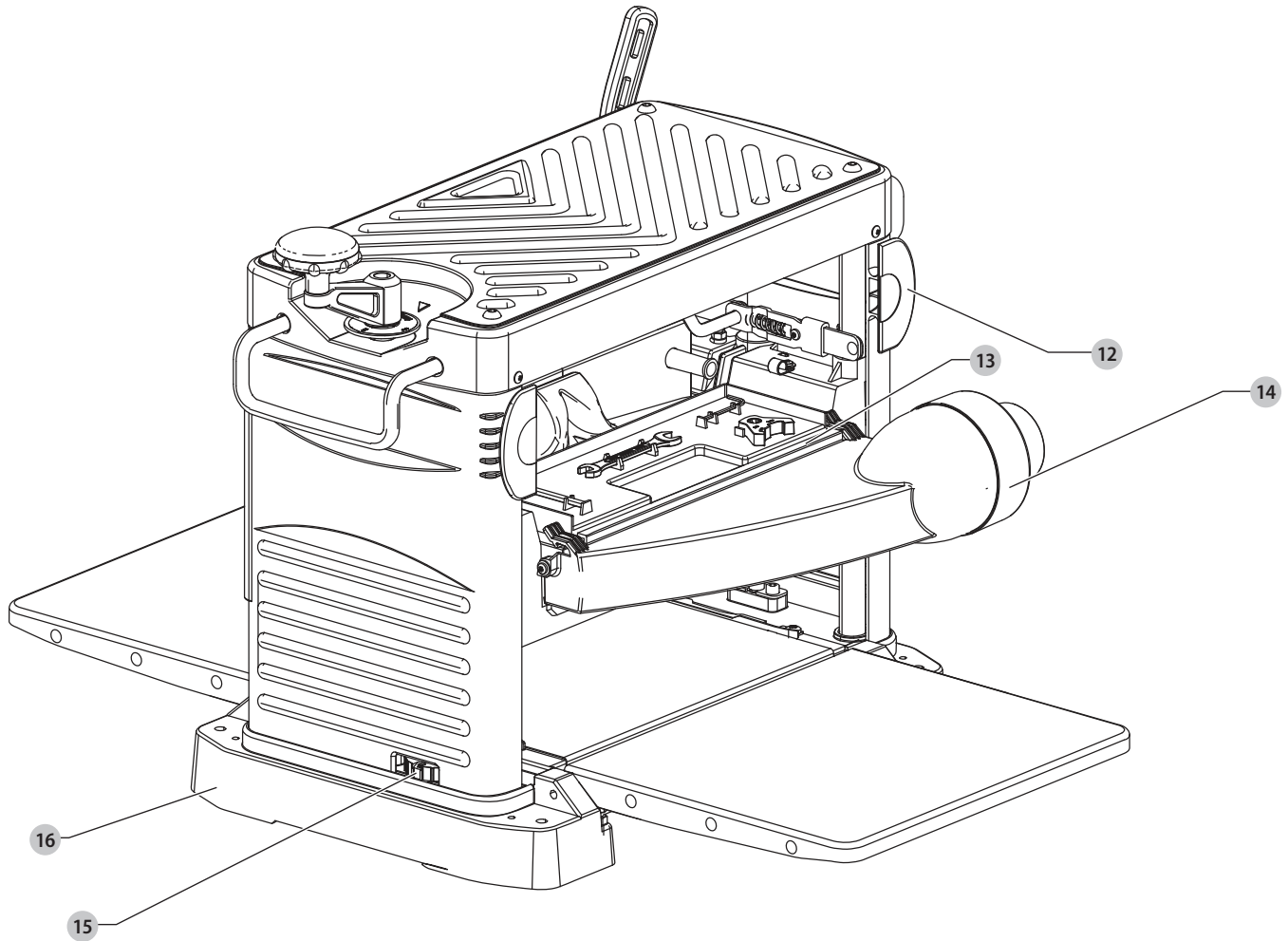

Fig. B

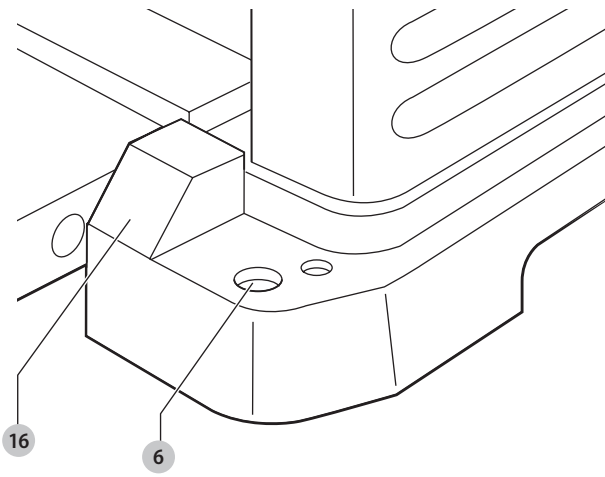

Fig. C1

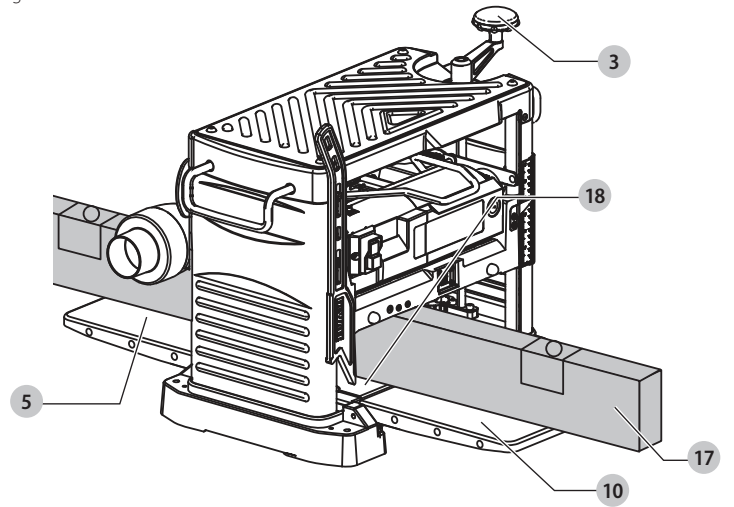

Fig. C2

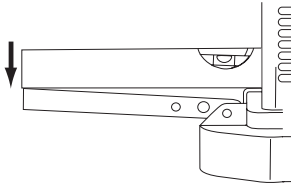

Fig. C3

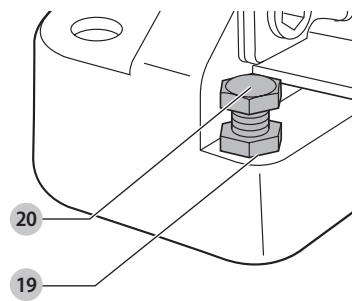

Fig. D1

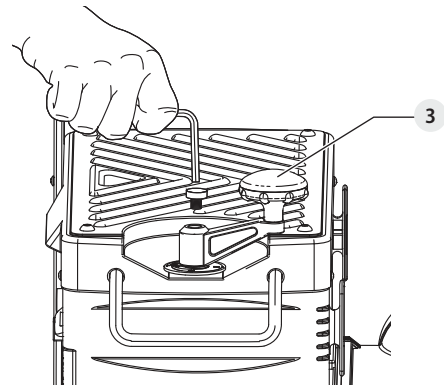

Fig. D2

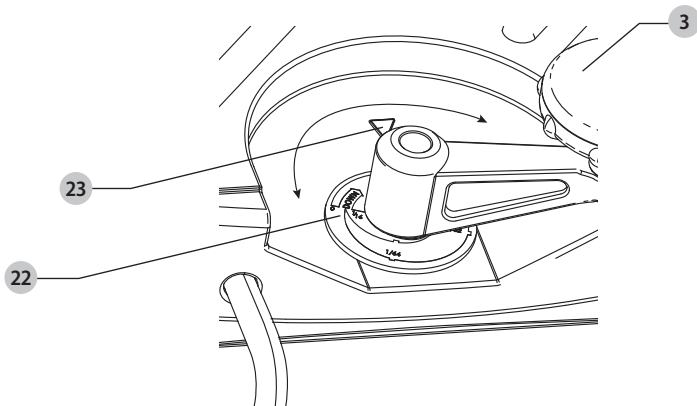

Fig. D3

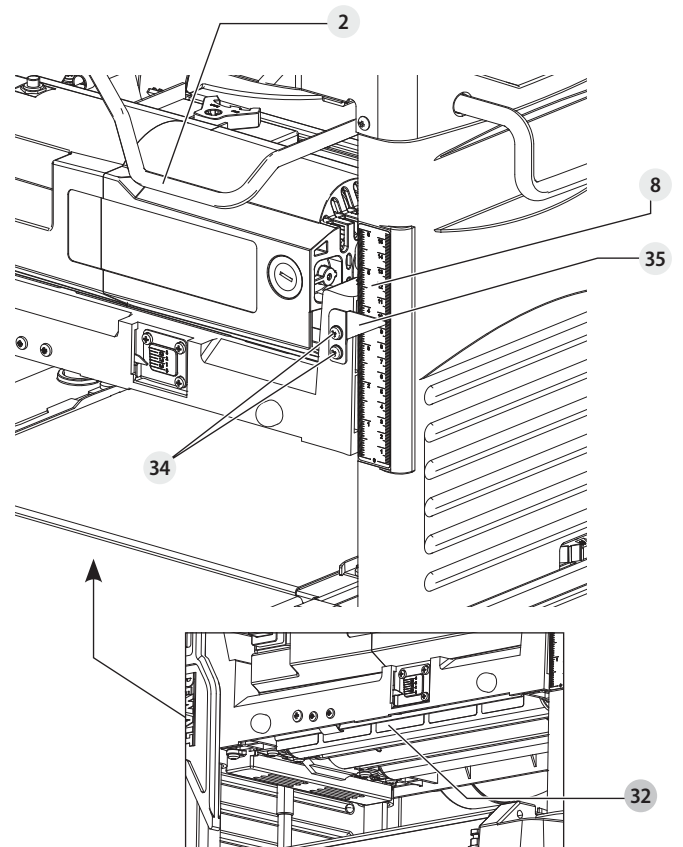

Fig. D4

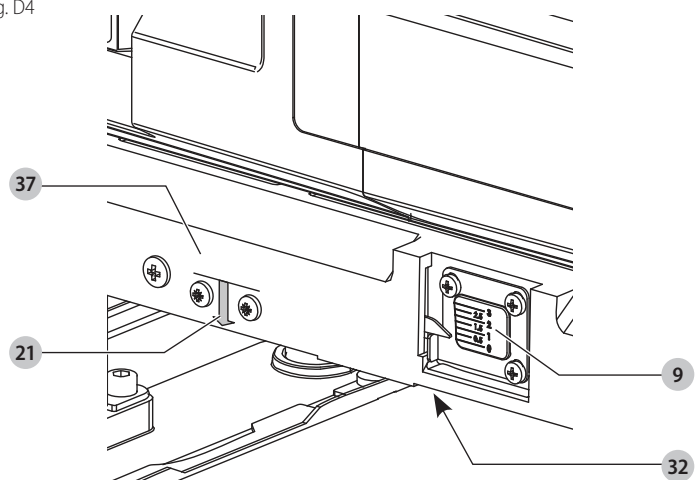

Fig. D5

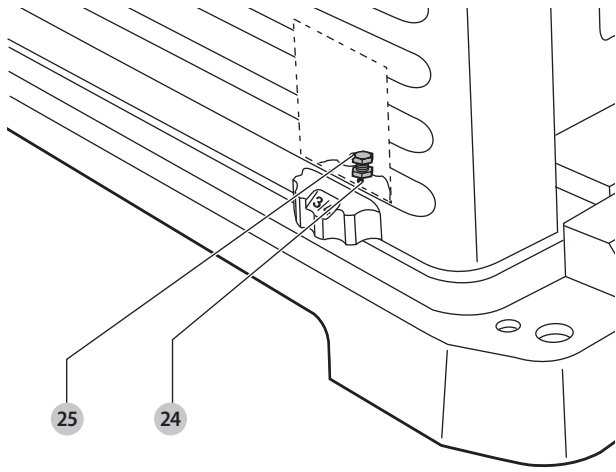

Fig. E1

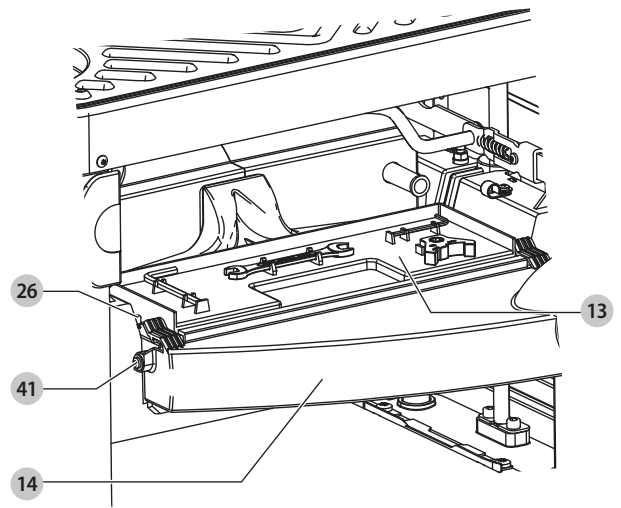

Fig. E2

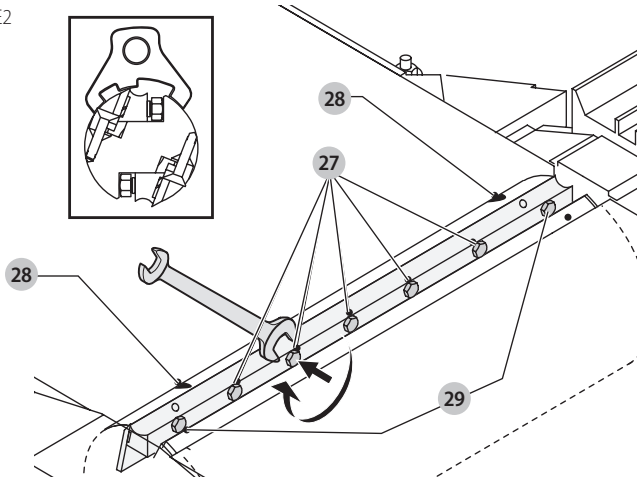

Fig. E3

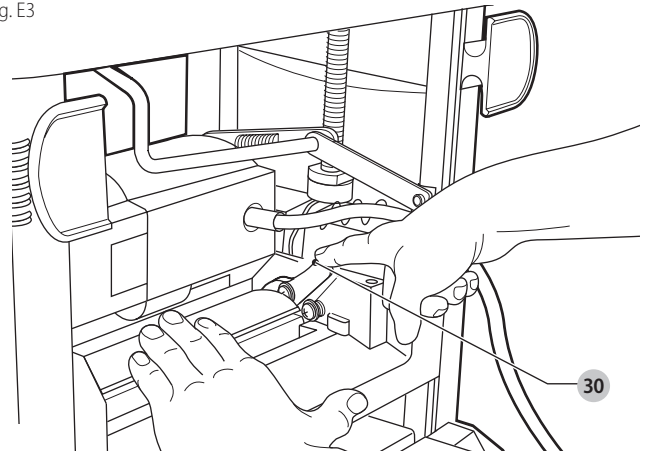

Fig. E4

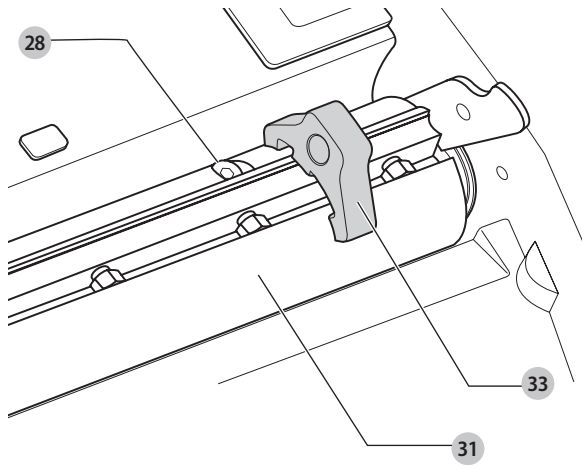

Fig. E5

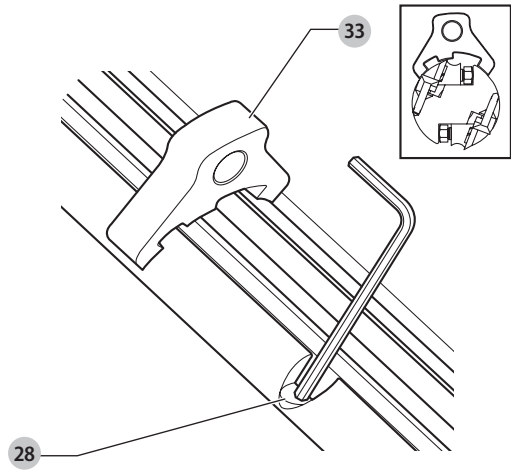

Fig. F1

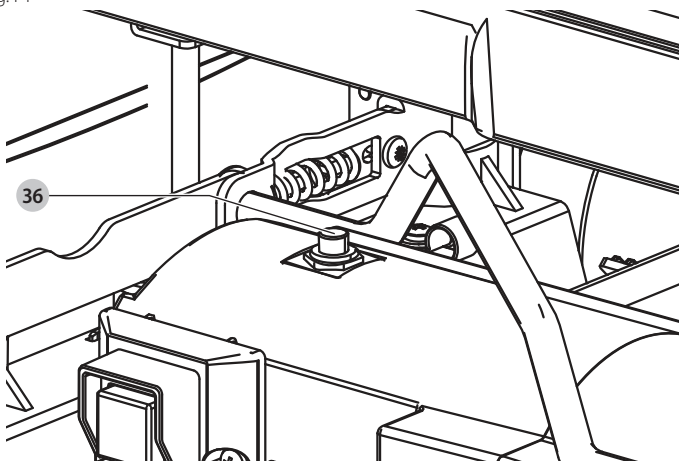

Fig. F2

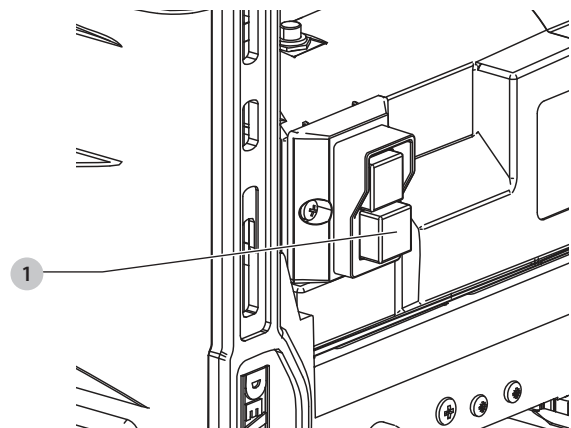

Fig. G

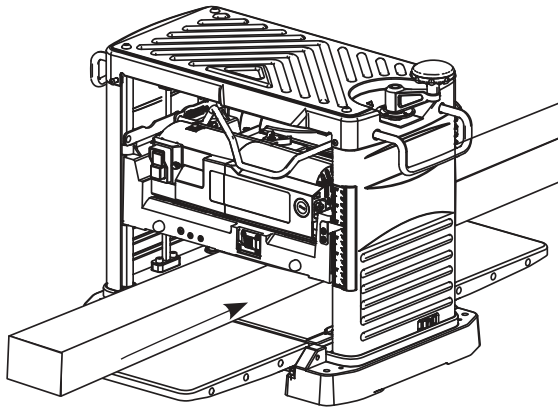

Fig. H1

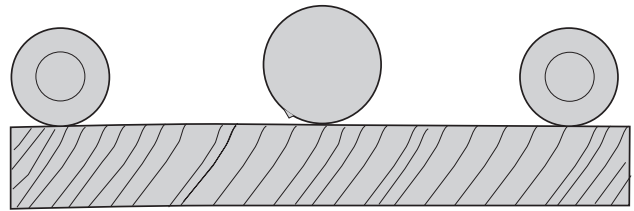

Fig. H2

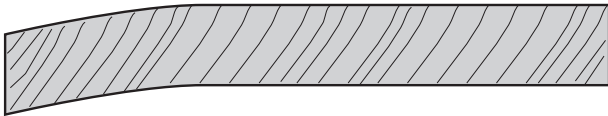

Fig. H3

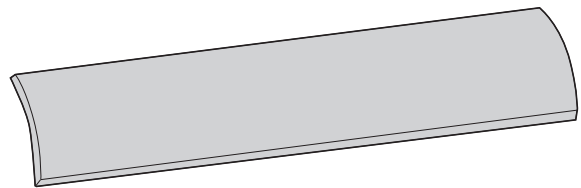

Fig. H4

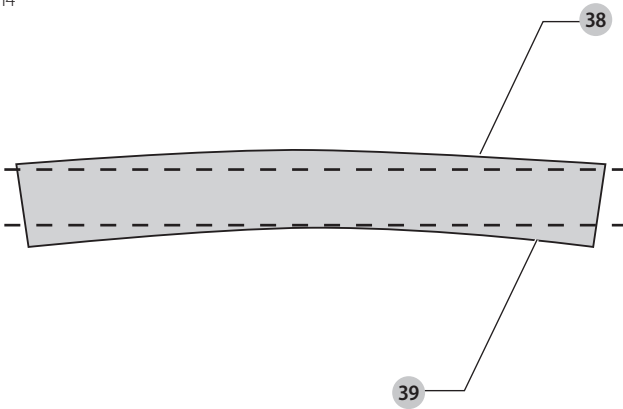
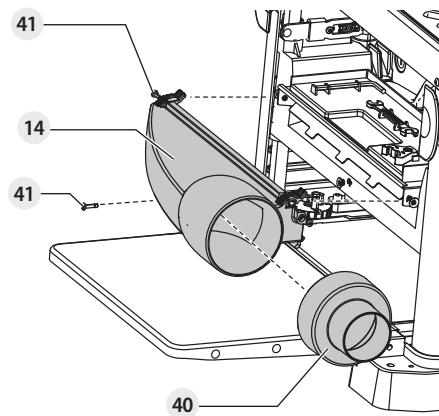

Fig. I



HEAVY-DUTY PORTABLE THICKNESS PLANER DW733

Congratulations!

You have chosen a DEWALT tool. Years of experience, thorough product development and innovation make DEWALT one of the most reliable partners for professional power tool users.

Technical Data

		DW733
Voltage	V _{AC}	230
Frequency	Hz	50
Type		11
Power input	W	1800
No load speed	min ⁻¹	10000
Feed speed	m/s	0.13
Cutting height (max.)	mm	152
Cutting height (min.)	mm	3.2
Cutting width (min. – max.)	mm	64–315
Max. cutting depth (for max. board width of 127 mm)	mm	Softwood: 3.2 Hardwood: 2.8
Weight	kg	36.2
Noise values and vibration values (triax vector sum) according to EN61029:		
L _{PA} (emission sound pressure level)	dB(A)	91.5
L _{WA} (sound power level)	dB(A)	102.2
K (uncertainty for the given sound level)	dB(A)	2.5

The vibration and/or noise emission level given in this information sheet has been measured in accordance with a standardised test given in EN61029 and may be used to compare one tool with another. It may be used for a preliminary assessment of exposure.

WARNING: The declared vibration and/or noise emission level represents the main applications of the tool. However if the tool is used for different applications, with different accessories or poorly maintained, the vibration emission may differ. This may significantly increase the exposure level over the total working period.

An estimation of the level of exposure to vibration and/or noise should also take into account the times when the tool is switched off or when it is running but not actually doing the job. This may significantly reduce the exposure level over the total working period.

Identify additional safety measures to protect the operator from the effects of vibration such as: maintain the tool and the accessories, keep the hands warm, organisation of work patterns.

NOTE: This device is intended for connection to a power supply system with maximum permissible system impedance Z_{max} of 0.17 Ω at the interface point (power service box) of user's supply.

The user has to ensure that this device is connected only to a power system which fulfils the requirement above. If necessary, the user can ask the public power supply company for the system impedance at the interface point.

EC-Declaration of Conformity

Machinery Directive



Heavy-Duty Portable Thickness Planer DW733

DEWALT declares that these products described under **Technical Data** are in compliance with: 2006/42/EC, EN61029-1:2009 +A11:2010, EN61029-2-3:2011.

These products also comply with Directive 2014/30/EU and 2011/65/EU. For more information, please contact DEWALT at the following address or refer to the back of the manual.

The undersigned is responsible for compilation of the technical file and makes this declaration on behalf of DEWALT.

Markus Rompel
Vice-President Engineering, PTE-Europe
DEWALT, Richard-Klinger-Straße 11,
65510, Idstein, Germany
09.07.2021

DECLARATION OF CONFORMITY

THE SUPPLY OF MACHINERY (SAFETY) REGULATIONS 2008



Heavy-Duty Portable Thickness Planer DW733

DEWALT declares that these products described under "technical data" are in compliance with: The Supply of Machinery (Safety) Regulations, 2008, S.I. 2008/1597 (as amended), EN61029-1:2009 +A11:2010, EN61029-2-3:2011

These products conform to the following UK Regulations

Electromagnetic Compatibility Regulations, 2016, S.I.2016/1091 (as amended).

The Restriction of the Use of Certain Hazardous Substances in Electrical and Electronic Equipment Regulations 2012, S.I. 2012/3032 (as amended).

For more information, please contact DEWALT at the following address or refer to the back of the manual.

The undersigned is responsible for compilation of the technical file and makes this declaration on behalf of DEWALT.

Karl Evans
Vice President Professional Power Tools EANZ GTS
DEWALT UK, 270 Bath Road, Slough
SL1 4DX
England
09.07.2021



WARNING: To reduce the risk of injury, read the instruction manual.

Definitions: Safety Guidelines

The definitions below describe the level of severity for each signal word. Please read the manual and pay attention to these symbols.



DANGER: Indicates an imminently hazardous situation which, if not avoided, **will** result in **death or serious injury**.



WARNING: Indicates a potentially hazardous situation which, if not avoided, **could** result in **death or serious injury**.



CAUTION: Indicates a potentially hazardous situation which, if not avoided, **may** result in **minor or moderate injury**.

NOTICE: Indicates a practice **not related to personal injury** which, if not avoided, **may** result in **property damage**.



Denotes risk of electric shock.



Denotes risk of fire.

Safety Instructions



WARNING: When using electric tools basic safety precautions should always be followed to reduce the risk of fire, electric shock and personal injury including the following.

Read all these instructions before attempting to operate this product and save these instructions.

SAVE THIS MANUAL FOR FUTURE REFERENCE

General Safety Rules

- Keep work area clear.**
 - Cluttered areas and benches invite injuries.
- Consider work area environment.**
 - Do not expose the tool to rain. Do not use the tool in damp or wet conditions. Keep the work area well lit (250–300 Lux). Do not use the tool where there is a risk of causing fire or explosion, e.g., in the presence of flammable liquids and gases.
- Guard against electric shock.**
 - Avoid body contact with earthed surfaces (e.g., pipes, radiators, cookers and refrigerators). When using the tool under extreme conditions (e.g., high humidity, when metal swarf is being produced, etc.), electric safety can be improved by inserting an isolating transformer or a (FI) earth-leakage circuit-breaker.
- Keep other persons away.**
 - Do not let persons, especially children, not involved in the work, touch the tool or the extension cord and keep them away from the work area.
- Store idle tools.**

- When not in use, tools must be stored in a dry place and locked up securely, out of reach of children.
6. **Do not force the tool.**
 - It will do the job better and safer at the rate to which it was intended.
 7. **Use the right tool.**
 - Do not force small tools to do the job of a heavy duty tool. Do not use tools for purposes not intended; for example do not use circular saws to cut tree limbs or logs.
 8. **Dress properly.**
 - Do not wear loose clothing or jewellery, as these can be caught in moving parts. Non-skid footwear is recommended when working outdoors. Wear protective hair covering to contain long hair.
 9. **Use protective equipment.**
 - Always use safety glasses. Use a face or dust mask if working operations create dust or flying particles. If these particles might be considerably hot, also wear a heat-resistant apron. Wear ear protection at all times. Wear a safety helmet at all times.
 10. **Connect dust extraction equipment.**
 - If devices are provided for the connection of dust extraction and collecting equipment, ensure these are connected and properly used.
 11. **Use only the push stick provided by the manufacturer.**
 - This push stick provides sufficient distance of the hand from the blade.
 - Never use a damaged or cut push stick. A damaged push stick may break causing your hand to slip into the blade.
 - If small workpieces are inserted by hand, there is an increased risk of injury. It's recommended to use the push-stick. Keep your hand at a safe distance from the blade.
 12. **Do not abuse the cord.**
 - **Never yank the cord to disconnect it from the socket.** Keep the cord away from heat, oil and sharp edges. Never carry the tool by its cord.
 13. **Secure work.**
 - Where possible use clamps or a vice to hold the work. It is safer than using your hand and it frees both hands to operate the tool.
 14. **Do not overreach.**
 - Keep proper footing and balance at all times.
 15. **Maintain tools with care.**
 - Keep cutting tools sharp and clean for better and safer performance. Follow instructions for lubricating and changing accessories. Inspect tools periodically and if damaged have them repaired by an authorized service facility. Keep handles and switches dry, clean and free from oil and grease.
 16. **Disconnect tools.**
 - When not in use, before servicing and when changing accessories such as blades, bits and cutters, disconnect tools from the power supply.
 17. **Remove adjusting keys and wrenches.**
 - Form the habit of checking to see that adjusting keys and wrenches are removed from the tool before operating the tool.
 18. **Avoid unintentional starting.**
 - Do not carry the tool with a finger on the switch. Be sure that the tool is in the "off" position before plugging in.
 19. **Use outdoor extension leads.**
 - Before use, inspect the extension cable and replace if damaged. When the tool is used outdoors, use only extension cords intended for outdoor use and marked accordingly.
 20. **Stay alert.**
 - Watch what you are doing. Use common sense. Do not operate the tool when you are tired or under the influence of drugs or alcohol.
 21. **Check for damaged parts.**
 - Before use, carefully check the tool and mains cable to determine that it will operate properly and perform its intended function. Check for alignment of moving parts, binding of moving parts, breakage of parts, mounting and any other conditions that may affect its operation. A guard or other part that is damaged should be properly repaired or replaced by an authorized service centre unless otherwise indicated in this instruction manual. Have defective switches replaced by an authorized service centre. Do not use the tool if the switch does not turn it on and off. Never attempt any repairs yourself.
-  **WARNING:** The use of any accessory or attachment or performance of any operation with this tool other than those recommended in this instruction manual may present a risk of personal injury.
22. **Have your tool repaired by a qualified person.**
 - This electric tool complies relevant safety rules. Repairs should only be carried out by qualified persons using original spare parts; otherwise this may result in considerable danger to the user.

- Ensure the machine is in perfect working condition. Never run the machine without all guards in place.
- Always use sharp blades of the correct type designed for the material to be cut. Do not use knives which are blunt as this increases the danger of kickback.
- Keep your hands well clear of the blades.
- Never plane material shorter than 500 mm.
- Refrain from removing any cut-offs or other parts of the workpiece from the cutting area whilst the machine is running.
- Without additional support the machine is designed to accept the maximum workpiece size of:
 - Width 315 mm by height 152 mm by length 1000 mm.
 - Longer workpieces need to be supported by suitable additional roller tables. The roller stands shall be placed in a distance to the inlet and outlet of the thickness planer to safely support the workpiece.
- Always keep the push stick in its store place when not in use.
- In case of an accident or machine failure immediately turn the machine off and disconnect from the mains.
- Report the failure and mark the machine in suitable form to prevent other people from using the defective machine.
- When the cutterhead is blocked due to abnormal feed force during cutting, turn the machine off and disconnect from power supply. Remove the workpiece and ensure that the cutterhead runs free. Turn the machine on and start new cutting operation with reduced feed force.
- Never use the machine for working any material other than wood. Examine the workpiece carefully for faults which may affect the machining process.
- Whenever the situation allows, clamp the machine to a bench.
- Ensure the blades are well sharpened. The blades can be re-sharpened up to 3 times. After that the blades must be replaced. Use only DEWALT blades and spare parts.
- Before use, check all safety related parts, such as switch, cutterhead, anti-kickback device and feed speed roller for proper function.
- Adjust the infeed and outfeed tables correctly.
- Wear safety gloves when handling the cutter block and rough material.
- Ensure the operator is adequately trained in the use, adjustment and operation of the machine.
- To reduce risk of injury, turn the machine off and disconnect from the power source before installing and removing accessories. Be sure the trigger switch is in the OFF position.
- Never carry out stopped work (i.e., cuts that do not involve working over the full length of the workpiece).
- Avoid working badly bowed wood providing inadequate contact with the infeed table.
- Don't step on the tool and extension tables.
- **Never stand directly in line with the workpiece. Always position your body on the side of the workpiece.** Kickback may propel the workpiece at high velocity towards anyone standing in front and in line with the workpiece.

 **WARNING:** We recommend the use of a residual current device with a residual current rating of 30mA or less.

Residual Risks

The following risks are inherent to the use of planers:

- Injuries caused by touching the rotating parts.

In spite of the application of the relevant safety regulations and the implementation of safety devices, certain residual risks cannot be avoided.

These are:

- Risk of accidents caused by the uncovered parts of the rotating blade.
- Risk of injury when changing the blade.
- Risk of squeezing fingers when opening the guards.
- Health hazards caused by breathing dust developed when planing wood, especially oak, beech and MDF.

The following factors increase the risk of breathing problems:

- No dust extractor connected when sawing wood.
- Insufficient dust extraction caused by uncleaned exhaust filters.
- Worn cutter blades.
- Infeed table not correctly adjusted.

Electrical Safety

The electric motor has been designed for one voltage only. Always check that the power supply corresponds to the voltage on the rating plate.

Your tool is Class I insulated in accordance with EN61029; therefore earth wire is required.

If the supply cord is damaged, it must be replaced only by DEWALT or an authorised service organisation.

Mains Plug Replacement (U.K. & Ireland Only)

If a new mains plug needs to be fitted:

- Safely dispose of the old plug.
- Connect the brown lead to the live terminal in the plug.
- Connect the blue lead to the neutral terminal.
- Connect the yellow/green lead to the earth terminal.

Additional Safety Rules for Thickness Planer

- It is advisable to wear safety goggles when operating.
- Make sure that the machine is placed on an even surface.
- Remove all nails and metal objects from the workpiece before starting work. Do not use splintery wood. There is a risk that parts will be ejected, kickback will occur and the knife will be damaged.
- Any portion of the cutter block not being used for planing shall be adjusted to be guarded.

WARNING: Follow the fitting instructions supplied with good quality plugs.
Recommended fuse: 13 A.

Using an Extension Cable

If an extension cable is required, use an approved 3-core extension cable suitable for the power input of this tool (see **Technical Data**). The minimum conductor size is 1.5 mm²; the maximum length is 30 m.

When using a cable reel, always unwind the cable completely.

Package Contents

The package contains:

- 1 Thickness planer
- 1 Open-ended key (8/10 mm)
- 2 Hex keys
- 1 Blade setting gauge
- 1 Dust extraction adaptor
- 1 Push stick
- 1 Instruction manual

Markings on Tool

The following pictograms are shown on the tool:

-  Read instruction manual before use.
-  Wear ear protection.
-  Wear eye protection.
-  Direction of workflow
-  Keep hands away from blade.
-  Carriage head lock
-  Material removal gauge
-  315mm Max. cutting width 315 mm
-  Turning direction of cutter block

Date Code Position (Fig. A1)

The date code **42**, which also includes the year of manufacture, is printed into the housing.
Example:

2021 XX XX
Year of Manufacture

Description (Fig. A1, A2)

WARNING: Never modify the power tool or any part of it. Damage or personal injury could result.

Fig. A1

- 1 ON/OFF switch
- 2 Head lock lever
- 3 Depth adjustment handle
- 4 Carrying handle
- 5 Rear table extension
- 6 Mounting holes
- 7 Handholds
- 8 Depth adjustment scale
- 9 Material removal scale
- 10 Front table extension
- 11 Push stick

Fig. A2

- 12 Cord wrap
- 13 Tool tray
- 14 Dust extraction adaptor
- 15 Depth stop
- 16 Base

Intended Use

Your DEWALT DW733 thickness planer has been designed for professional cutting of wood. It performs planing operations accurately and safely.

With the thickness planer you can plane debarked, rectangular sawn timber of all kinds to the desired width and thickness. The thickness planer was specially designed for planing solid wood. The device is not suitable for cutting rebates, indentations, tenons or shapes. Metal parts or splintering material must not be processed with this device. Do not work on wood that has numerous knots or knotholes. Make sure that the workpiece does not contain any cables, ropes, cords, nails or the like.

DO NOT use under wet conditions or in the presence of flammable liquids or gases.

This thickness planer is a professional power tool.

DO NOT let children come into contact with the tool. Supervision is required when inexperienced operators use this tool.

- **Young children and the infirm.** This appliance is not intended for use by young children or infirm persons without supervision.
- This product is not intended for use by persons (including children) suffering from diminished physical, sensory or mental abilities; lack of experience, knowledge or skills unless they are supervised by a person responsible for their safety. Children should never be left alone with this product.

WARNING: Do not use the machine for other purposes than intended.

UNPACKING

- The machine must be lifted out of the packaging by two people.
- Check for damage to the tool, parts or accessories which may have occurred during transport.
- Take the time to thoroughly read and understand this manual prior operation.
- Check if everything is complete.

ASSEMBLY AND ADJUSTMENTS

WARNING: To reduce the risk of serious personal injury, turn tool off and disconnect tool from power source before making any adjustments or removing/installing attachments or accessories. An accidental start-up can cause injury.

WARNING: The machine must be securely fastened at a bench with suitable screws, as there is a risk of tipping over.

Bench Mounting (Fig. B)

- Holes **6** are provided in all four feet to facilitate bench mounting. Two different sized holes are provided to accommodate different sizes of bolts. Use either hole; it is not necessary to use both. Always mount your machine firmly to prevent movement. To enhance portability, the tool can be mounted to a piece of 12.5 mm or thicker plywood which can then be clamped to your work support or moved to other job sites and reclamped.
- When mounting your machine to a piece of plywood, make sure that the mounting screws do not protrude from the bottom of the wood. The plywood must sit flush on the work support.
- To prevent binding and inaccuracy, be sure the mounting surface is not warped or otherwise uneven.

WARNING: The machine must be level and stable at all times.

Dust Extraction (Fig. A2, I)

Dust from materials such as lead-containing coatings and some wood types, can be harmful to one's health. Breathing-in the dust can cause allergic reactions and/or lead to respiratory infections of the user or bystanders. Certain dust, such as oak or beech dust, is considered carcinogenic, especially in connection with wood treatment additives.

Observe the relevant regulations in your country for the materials to be worked.

The vacuum cleaner must be suitable for the material being worked.

When vacuuming dry dust that is especially detrimental to health or carcinogenic, use dust class M vacuum cleaner.

The machine is provided with a dust extraction adaptor **14** at the rear of the machine suitable for use with dust extraction equipment featuring 101 mm nozzles. Supplied with the machine is a reduction bush **40** for use of dust extraction nozzles of 62,5 mm diameter.

During all operations, connect a dust extraction device designed in accordance with the relevant regulations regarding dust emission.

Attach the dust extraction to the back of the planer as shown in Fig. I and Fig. A2. Tighten all screws **41** securely. Attach vacuum adaptor.

Anti-Kickback Device (Fig. A1, D3, D4)

Before the tool is plugged in, turn the depth adjustment handle **3** to the appropriate position. The anti-kickback device **32** under the carriage **37**. Check to see if it is bent or broken.

Table Extensions (Fig. C1–C3)

1. Fold down the table extensions **5** and **10** (Fig. C1).
 - a. Place a level **17** over the table extensions and the main table **18**.
 - b. Press the edge of the table extensions down to remove any play.
2. The outside edges of the extension tables are level with the base while the inside edges (closest to the cutterhead) are below the edge of the base (Fig. C2).
3. If adjustment is required, proceed as follows: slacken the nuts **19** and adjust the bolts **20** until the tables are level (Fig. C3).

To Attach the Depth Adjustment Handle (Fig. D1)

1. Insert the depth adjustment handle **3** over the shaft.
2. Secure the depth adjustment handle in place with the screw and hex key provided.

Depth Adjustment (Fig. A2, D1–D4)

Your DW733 is equipped with a high precision depth adjustment system including a depth adjustment scale **8** (Fig. D3), a material removal scale **9** (Fig. D4), a fine adjuster and a depth stop **15** (Fig. A2).

1. Unlock the head lock lever **2** (Fig. D3) by pulling it up.
2. To attach the depth adjustment handle **3** (Fig. D1). One turn corresponds to a change in cutting depth of approx. 1.5 mm.
 - Turn clockwise to decrease the cutting depth.
 - Turn counterclockwise to increase the cutting depth (Fig. D2).
 - Observe the setting of the cutting depth and cutting width shown in Fig. G.
3. Read the finished thickness of your workpiece on the depth adjustment scale **8** (Fig. D3).
4. Make sure the material is under the material removal gauge **21**. Read the amount of wood being removed on the material removal scale **9** (Fig. D4).
5. Lock the head lock lever **2** (Fig. D3).

Fine Adjustment (Fig. D2)

Fine adjustments are ideal for shaving small amounts from planed material. For example, if your planed workpiece is 77.5 mm and should be 76.0 mm, proceed as follows:

1. Turn the circular label **22** until the 0 mark aligns with the arrow **23**. Do not make any other adjustments.
2. Turn the depth adjustment handle **3** clockwise until the 1.5 mm mark aligns with the arrow.
3. Plane your workpiece. The final thickness is now 76.0 mm.

Depth Stop (Fig. A2, D3, D5)

The depth stop **15** (Fig. A2) can be used for repetitive planing of preset depths. Stops are set at 0, 6, 12 and 19 mm.

Use the 0 mm stop for cutting depths between 3.2 and 6 mm.

1. Turn the depth stop until the desired measurement is indicated.
2. Unlock the head lock lever **2** (Fig. D3) and turn the depth adjustment handle clockwise until it contacts the depth stop. Do not turn the handle any further.

Use the 19 mm stop for other thicknesses. This will not affect the other depth stop settings.

1. Unlock the head lock lever **2** and turn the depth adjustment handle **3** counterclockwise to raise the head fully.
2. Loosen the nut **24** and adjust the depth adjustment bolt **25** as required (Fig. D5).
3. Turn the depth adjustment handle until it contacts the depth stop. Do not turn the handle any further.
4. Plane your workpiece and check its thickness. Make additional adjustments if required.

Calibrating the Depth Adjustment Scale (Fig. D3)

The depth adjustment scale **8** is factory set. In the case of extended use, it is recommended to check the scale for accuracy.

Plane a piece of wood, noting the measurement on the depth adjustment scale **8**.

If adjustment is required, proceed as follows:

1. Loosen the screws **34**.
2. Adjust the indicator **35** until its reading matches the finished thickness of the workpiece.
3. Firmly tighten the screws **34**.

Consult your dealer for further information on the appropriate accessories. These include spare blades (1004540-00).

Changing Blades (Fig. A1, A2, E1–E5)

WARNING: Use only cutting blades designed for this machine.

WARNING: Wear gloves when changing blades because of sharp edges.

Your DW733 is equipped with a cutterhead which holds two blades. For new blades contact DEWALT or an authorised service organisation.

WARNING: Sharp edges.

WARNING: The blades can be re-sharpened max. 3 mm down from their original size. If the blade size has decreased by more than 3 mm, the blades have to be replaced. The blades can be re-sharpened at 42°.

Removing the Blades (Fig. A1, A2, E1–E4)

1. Unlock the head lock lever **2** (Fig. A1).
2. Adjust the depth of cut to approx. 75 mm.
3. Loosen the three screws **41**, then rotate and remove the dust extraction adaptor **14** (Fig. A2).
4. Remove the two hex screws **26** (Fig. E1) and carefully remove the tool tray **13** (Fig. A2) to expose the blades.
5. Carefully rotate the cutterhead **31** (Fig. E4) until the first blade becomes visible.
6. Lock the head lock lever **2** (Fig. A1).
7. Loosen the seven blade clamping screws (**27**, **29**) (Fig. E2) using the wrench supplied.

8. Remove the blade from the cutterhead for re-sharpening or replacement.
9. Press the cutterhead locking lever **30** (Fig. E3) and slowly rotate the cutterhead until the other blade can be removed.

Replacing the Blades (Fig. E2–E5)

WARNING: Make sure that the cutting blades are properly adjusted. Do not allow the blades to protrude from the cutterhead by more than 1.1 mm.

NOTE: Before installing the knife, ensure the cutterhead and knife are free of debris; clean if needed.

1. Position the cutterhead **31** as shown in Figure E4.
2. Place the blade in the cutterhead and ensure that the head of the height adjustment screw **28** (Fig. E4) locates into the blade slot.
3. Loosen the seven screws (**27**, **29**) (Fig. E2) on the blade clamp against the blade a little bit to allow the blade to be adjusted for height.
4. Place the gauge **33** (Fig. E4) on the cutterhead as close as possible to the height adjustment screw **28** while still allowing movement of the hex key.
5. Turn one height adjustment screw **28** with the hex key until the blade tip touches the gauge **33** (Fig. E5). Repeat the procedure with the other height adjustment screw. Check to ensure the blade height is even. Repeat this procedure if needed.
6. Tighten the two end clamping screws **29** (Fig. E2) to 8.0 Nm.
7. Remove the gauge and tighten the five middle clamping screws **27** (Fig. E2) to 8.0 Nm.
8. Press the cutterhead locking lever **30** (Fig. E3) and slowly rotate the cutterhead until the other blade can be replaced following the above procedure.

OPERATION

Instructions for Use

WARNING: Always observe the safety instructions and applicable regulations.

WARNING: To reduce the risk of serious personal injury, turn tool off and disconnect tool from power source before making any adjustments or removing/installing attachments or accessories. An accidental start-up can cause injury.

WARNING: Make sure there is sufficient space for the workpiece at the outfeed side.

The attention of UK users is drawn to the "woodworking machines regulations 1974" and any subsequent amendments.

Ensure the machine is placed to satisfy your ergonomic conditions in terms of table height and stability. The machine site shall be chosen so that the operator has a good overview and enough free surrounding space around the machine that allows handling of the workpiece without any restrictions.

The workpiece may only be inserted into the machine from the side on which the circuit breaker is located. Note the arrow on the top of the device.

To reduce effects of vibration make sure the ambient temperature is not too cold, the machine and accessories are well maintained and the workpiece size is suitable for this machine.

Switching On and Off (Fig. F1, F2)

The On/Off switch of your DW733 is equipped with a circuit breaker. In case of motor overload, the power supply to the motor will be cut off. If this happens, turn the machine off and press the reset button **36** (Fig. F1).

- The workpiece should not be in contact with the cutterhead when switching on.

To turn on, press the green start button of the switch **1** (Fig. F2). The tool now works in continuous operation.

- Allow the motor to reach full speed before feeding the workpiece.
- Allow the blades to cut freely. Do not force.

To switch off, press the red stop button of the switch **1**.

WARNING: Always turn off the tool when work is finished and before unplugging.

Planing (Fig. G)

WARNING:

- Remove all foreign objects. Do not plane wood with loose knots. Do not plane wood that is severely knotted or warped.
- Your DW733 works best with at least one flat surface.
- For optimal results, plane both sides of your workpiece to reach the desired thickness.

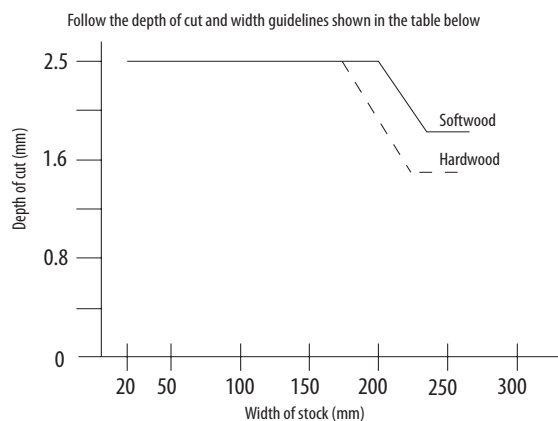

 **WARNING:** Feed the workpiece in the direction of the grain (Fig. G).

Snipe

Snipe is a depression made when the ends of the workpiece contact the cutters. To avoid snipe:

- Make sure the extension tables are level with the main table.
- Keep the workpiece level throughout the planing operation.
- Feed the workpiece flat against the tables.

Warping (Fig. H1–H4)

If your workpiece is only slightly warped, plane both sides to produce the desired thickness.

Bowed Workpieces (Fig. H1, H2)

The feed rollers and cutterhead will temporarily flatten the workpiece (Fig. H1). The bowed shape, however, will return after planing (Fig. H2).

To remove the bow, use a jointer.

Cupped Workpieces (Fig. H3, H4)

1. Rip the cupped workpiece in the middle (Fig. H3).
2. Plane the pieces separately to eliminate waste.
3. Alternatively, plane the top flat **38** first, then turn the workpiece over and plane the bottom flat **39** (Fig. H4).

Transporting (Fig. A1, A2)

- Always transport the machine disconnected from power supply.
- Wind the supply cord at the cord wrap **12** to keep cord in place.
- Always carry the machine by both carrying handles **4** or handholds **7**.
- The machine should be carried by two persons.
- Check the tool for damage before use after transporting.

Storage

- Always store the machine switched off and disconnected from power supply.
- Store the tool at a cool and dry place.
- Store the tool in a place where they cannot be accessed by children or unauthorized person.
- Check the machine for damage before using after a long period of storage.

MAINTENANCE

Your DEWALT power tool has been designed to operate over a long period of time with a minimum of maintenance. Continuous satisfactory operation depends upon proper tool care and regular cleaning.

 **WARNING:** To reduce the risk of serious personal injury, turn tool off and disconnect tool from power source before making any adjustments or removing/installing attachments or accessories. An accidental start-up can cause injury.

Resharpener the Blades

The blades can be resharpened at 42 °.





Lubrication

Your power tool requires no additional lubrication.



Cleaning

 **WARNING:** Vacuum dirt and dust out of the main housing with a suitable vacuum cleaner as often as dirt is seen collecting in and around the air vents. Wear approved eye protection and approved dust mask when performing this procedure.

 **WARNING:** Never use solvents or other harsh chemicals for cleaning the non-metallic parts of the tool. These chemicals may weaken the materials used in these parts. Use a cloth dampened only with water and mild soap. Never let any liquid get inside the tool; never immerse any part of the tool into a liquid.

 **WARNING:**

- Keep the tables clean and free from grease. Regularly apply some wax to the tables.
- Keep the machine free from dust and shavings.

Before use, carefully check the cutterhead to determine that it will operate properly. Ensure that dirt, dust or workpiece particles cannot lead to blockage of one of the functions.

In case of workpiece fragments jammed between cutterhead and infeed roller, disconnect the machine from the power supply and remove the jammed parts.

Optional Accessories

 **WARNING:** Since accessories, other than those offered by DEWALT, have not been tested with this product, use of such accessories with this tool could be hazardous. To reduce the risk of injury, only DEWALT recommended accessories should be used with this product.

Consult your dealer for further information on the appropriate accessories.

Protecting the Environment



Separate collection. Products and batteries marked with this symbol must not be disposed of with normal household waste.

Products and batteries contain materials that can be recovered or recycled reducing the demand for raw materials. Please recycle electrical products and batteries according to local provisions. Further information is available at www.2helpU.com.

Belgique et Luxembourg België en Luxemburg	DeWALT - Belgium BVBA Egide Walschaertsstraat 16 2800 Mechelen	Tel: NL 32 15 47 37 63 Tel: FR 32 15 47 37 64 Fax: 32 15 47 37 99	www.dewalt.be enduser.BE@sbdinc.com
Danmark	DeWALT (STANLEY BLACK&DECKER AS) Roskildevej 22 2620 Albertslund	Tel: 70 20 15 10 Fax: 70 22 49 10	www.dewalt.dk kundeservice.dk@sbdinc.com
Deutschland	DeWALT Richard Klinger Str. 11 65510 Idstein	Tel: 06126-21-0 Fax: 06126-21-2770	www.dewalt.de infodwge@sbdinc.com
Ελλάς	DeWALT (Ελλάς) Α.Ε. ΕΔΡΑ-ΓΡΑΦΕΙΑ : Στραβίου 7 & Λ. Βουλιαγμένης, Γλυφάδα 166 74, Αθήνα SERVICE : Ημερος Τόπος 2 (Χάνι Αδάμ) – 193 00 Ασπρόπυργος	Τηλ: 00302108981616 Φαξ: 00302108983570	www.dewalt.gr Greece.Service@sbdinc.com
España	DeWALT Ibérica, S.C.A. Parc de Negocios "Mas Blau" Edificio Muntadas, c/Bergadá, 1, Of. A6 08820 El Prat de Llobregat (Barcelona)	Tel: 934 797 400 Fax: 934 797 419	www.dewalt.es respuesta.postventa@sbdinc.com
France	DeWALT (Stanley Black & Decker France SAS) 62 Chemin de la Bruyère CS 60105, 69574 DARDILLY Cedex	Tel: 04 72 20 39 20 Fax: 04 72 20 39 00	www.dewalt.fr scufr@sbdinc.com
Schweiz Suisse Svizzera	DeWALT In der Luberzen 42 8902 Urdorf	Tel: 044 - 755 60 70 Fax: 044 - 730 70 67	www.dewalt.ch service@rofoag.ch
Ireland	DeWALT Building 4500, Kinsale Road Cork Airport Business Park Cork, Ireland	Tel: 00353-2781800 Fax: 01278 1811	www.dewalt.ie Sales.ireland@sbdinc.com
Italia	DeWALT via Energypark 6 20871 Vimercate (MB), IT	Tel: 800-014353 39 039-9590200 Fax: 39 039-9590311	www.dewalt.it
Nederlands	DeWALT Netherlands BVPostbus 83, 6120 AB BORN	Tel: 31 164 283 063 Fax: 31 164 283 200	www.dewalt.nl
Norge	DeWALT Postboks 4613 0405 Oslo, Norge	Tel: 45 25 13 00 Fax: 45 25 08 00	www.dewalt.no kundeservice.no@sbdinc.com
Österreich	DeWALT Werkzeug Vertriebsges m.b.H Oberlaaerstrasse 248, A-1230 Wien	Tel: 01 - 66116 - 0 Fax: 01 - 66116 - 614	www.dewalt.at service.austria@sbdinc.com
Portugal	DeWALT Ed. D Dinis, Quina da Fonte Rua dos Malhoes 2 2A 2º Esq. Oeiras e S. Juliao da Barra, paço de Arcos e Caxias 2770 071 Paço de Arcos	Tel: +351 214667500 Fax: +351214667580	www.dewalt.pt resposta.posvenda@sbdinc.com
Suomi	DeWALT PL47 00521 Helsinki, Suomi	Puh: 010 400 4333 Faksi: 0800 411 340	www.dewalt.fi asiakaspalvelu.fi@sbdinc.com
Sverige	DeWALT BOX 94 43122 Mölndal Sverige	Tel: 031 68 61 60 Fax: 031 68 60 08	www.dewalt.se kundservice.se@sbdinc.com
Türkiye	Sanayi ve Ticaret Bakanlığı tebliğince kullanım ömrü 7 yıldır. Stanley Black & Decker Turkey Alet Üretim San. Tic. Ltd.Şti. AND Kozyatağı - İçerenköy Mah. Umut Sok. AND Ofis Sit. No: 10-12 / 82-83-84 Ataşehir/İstanbul, Türkiye	Tel: +90 216 665 2900 Faks: +90 216 665 2901	www.dewalt.com.tr support@dewalt.com.tr
United Kingdom	DeWALT, 210 Bath Road; Slough, Berks SL1 4DX	Tel: 01753-567055 Fax: 01753-572112	www.dewalt.co.uk emeaservice@sbdinc.com
Australia	DeWALT 810 Whitehorse Road Box Hill VIC 3128 Australia	Tel: Aust 1800 338 002 Tel: NZ 0800 339 258	www.dewalt.com.au www.dewalt.co.nz
Middle East Africa	DeWALT P.O. Box - 17164, Jebel Ali Free Zone (South), Dubai, UAE	Tel: 971 4 812 7400 Fax: 971 4 2822765	www.dewalt.ae support@dewalt.ae